



Selection Guide for CNC Rotary Tables ...

**Smart
Solution**

We will
support you

2026



SAEILO

02/2026 | EN

... for vertical machining centers

CNC rotary tables for economical manufacturing:
pL LEHMANN has suitable and rational solutions for
nearly every industry

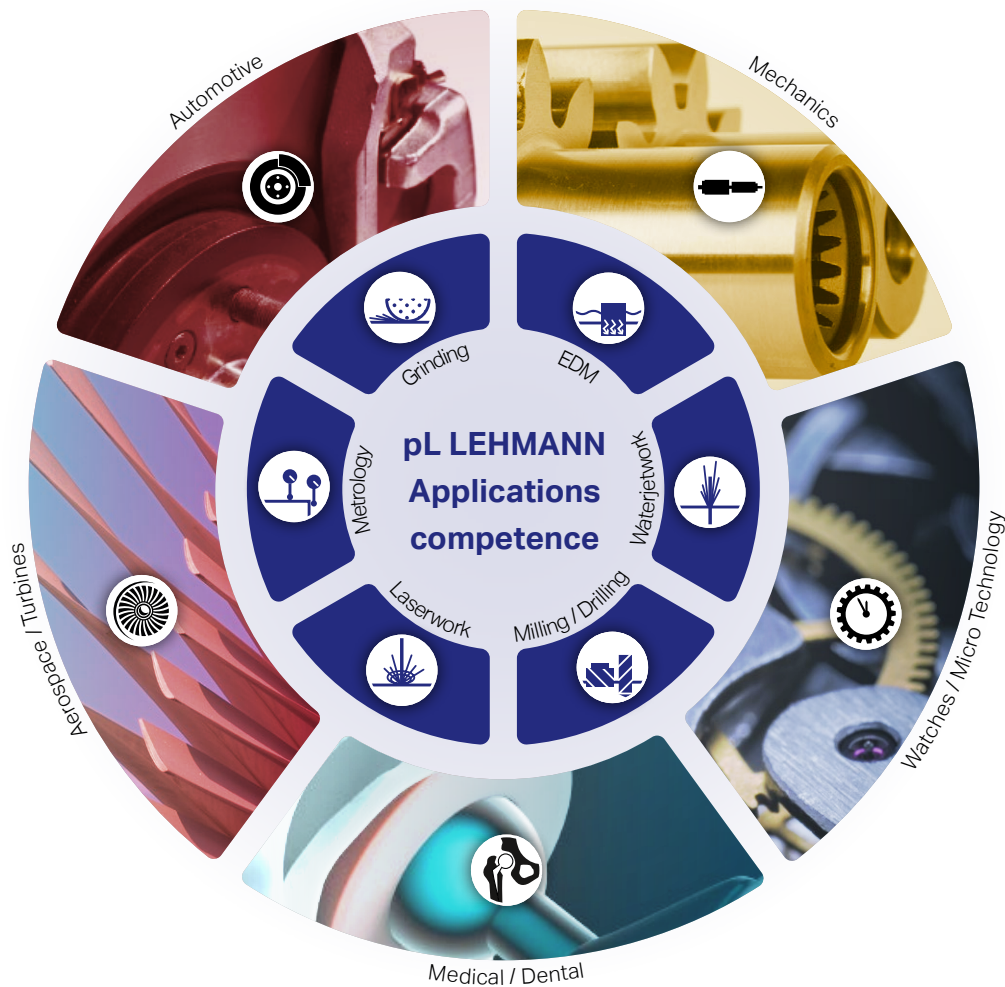

pL rotary tables in use on over **200** different machine brands and
over **1,000** different machine models.

pL competence: Integration in **all known** CNC control systems
(Fanuc, Siemens, Heidenhain, Haas, Winmax, Mitsubishi, Brother, Ma-
zatzol ...), for new machines as well as for retrofits

Professional products from professional partners:
 SAEILO and pL LEHMANN provide
 first-class service to common customers

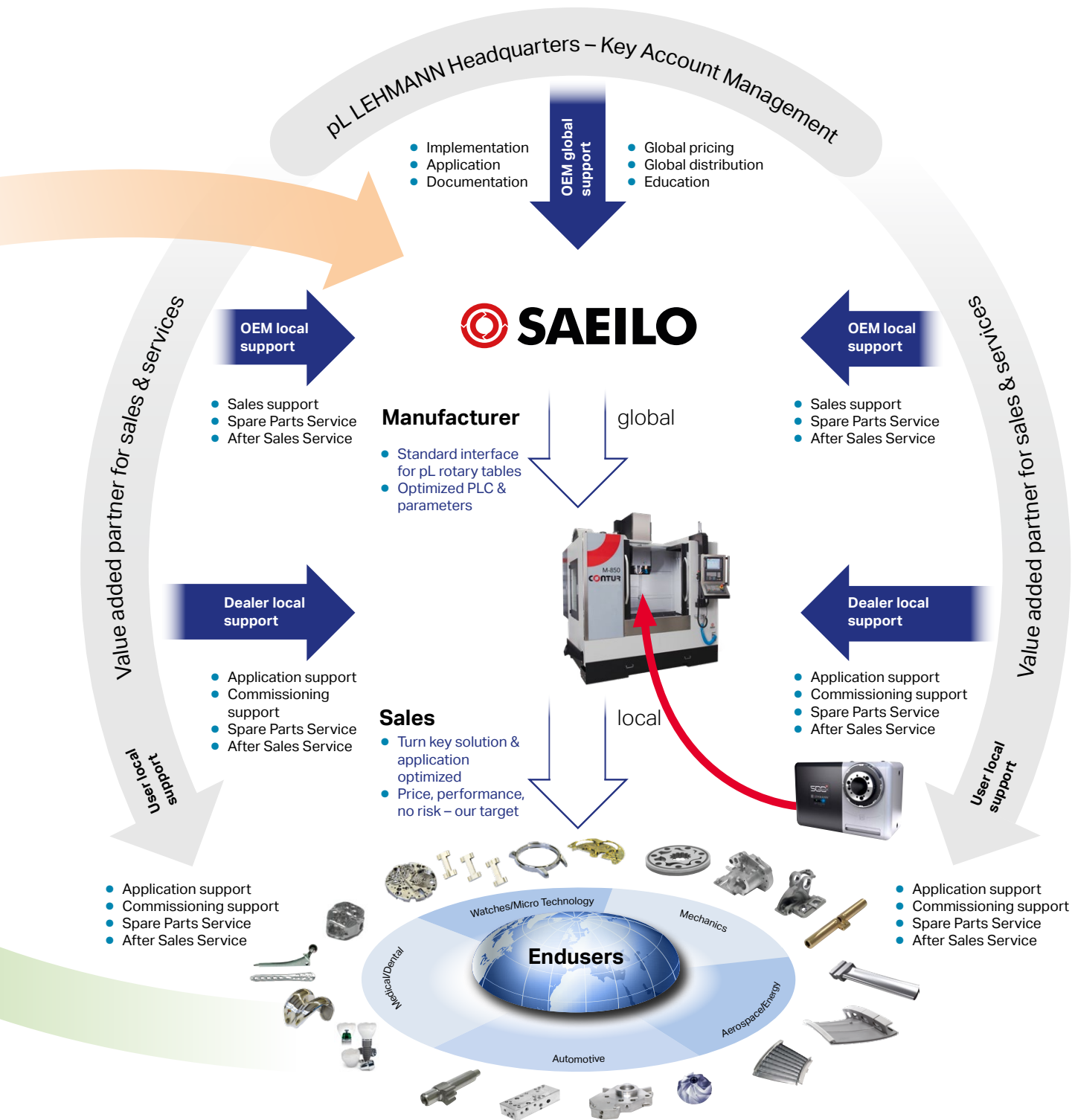

Up to 210 rpm
up to 0.21 sec / 90°

High speed GD

Extended travel in
Z- and X-direction

More space

High spindle load,
heavy-duty bearing

Heavy duty

E-Series



EA-50x light only 12 kg



DD Series

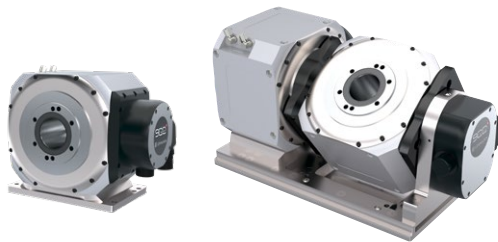

**Request our
special catalog**

High speed DD

up to 3'300 rpm

Adaptability

Multifunctional
spindle HSK

Precision

On the workpiece, as
precise as 2 μ m / 100 mm

Pneum. clamping
up to 7,000 Nm

High clamp

Large parts
up to \varnothing 500

Big size

PGD backlash-free
long-life gear unit

No backlash

T-Series



**All base plates
made of steel**

with integrated hole pattern for
slot spacing of 100 and 125 mm,
integrated alignment system
lineFIX for lengthwise or cross-
wise clamping.

M-Series



Connectivity

Monitoring for
operation & service

No adjust

Load change without
parameter adjustment

Less cost

No cooling system,
no hydraulics



M-600



M-850



M-1000

A word from SAEILO:

«SAEILO – the way to connect people

SAEILO delivers high-quality and reliable machine tools for turning, milling, and grinding at top prices.

Development always adheres to the highest quality standards.

We take the time to understand your needs and wishes as thoroughly as possible and work with you to find the perfect machine solution.»



M-1600



MMV-1100



MMV-1500



MMV-2000

The right machine/rotary table combination for economical production: this Selection Guide helps you make the right selection

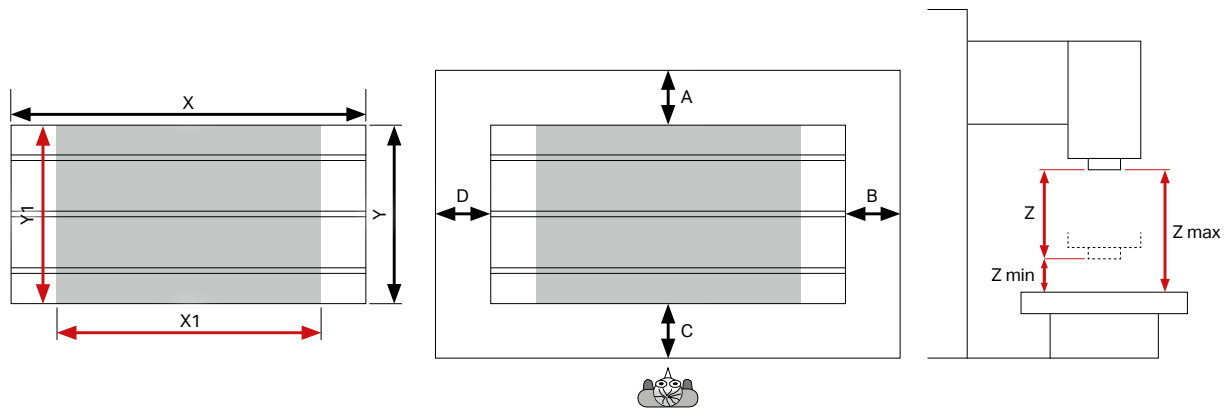

	Table diameter [mm]		Permissible overhang *	Traverse stroke [mm]					Minimum distance [mm]				Table load ** max [kg]
	X	Y		X1	Y1	Z	Zmin	Zmax	A	B	C	D	
M-600	800	450	10%	600	450	520	110	630					450
M-850	1'000	550	10%	850	550	550	150	700					800
M-1000	1'100	600	10%	1'000	620	700	150	850					1'200
M-1200	1'300	600	10%	1'200	600	800	110	910					1'400
M-1600	1'700	700	10%	1'600	720	700	150	850					1'600
MMV-1100	1'200	700	10%	1'120	700	700	100	800					1'000
MMV-1300	1'400	700	10%	1'320	700	700	100	800					1'600
MMV-1500	1'600	700	10%	1'520	700	700	100	800					1'600
MMV-1800	2'000	1'000	10%	1'820	1'000	880	100	980					3'000
MMV-2000	2'200	1'000	10%	2'020	1'000	880	100	980					3'500

* The recommended rotary tables can overhang the machine table by so many % (e.g. 10 % means: the rotary table length can be greater than dimension Y or X by max. 10 % of the machine width Y with Y-clamping or 10 % of the table length X with X-clamping.)
 ** The recommended rotary tables do not exceed 50 % of the allowed table load.

Table explanation for pp. 8–11

	EA-507	EA-510	EA-520	EA-530	EA-913	EA-915	EA-918
	X2						
M-600	533	517	491		497	497	447

Wherever values are listed, the combination is recommended. Empty cells mean that a combination is not possible, because the rotary table is too large, or is not recommended, because the rotary table is disproportionately small or heavier than 50% of the table load.

Y-mounting

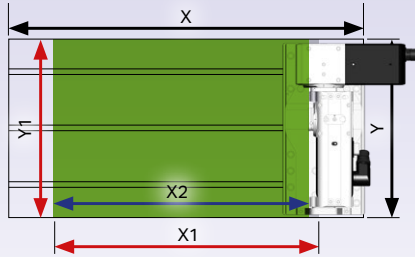

Rotary table installation using hole pattern in base plate



TIP1



TAP1



TOP1.2

	TIP1c TF-507510	TIP2c TF-510520	TIP3c TF-520530	TAP1c T1-507510	TAP2c T1-510520	TAP3c T1-520530	TAP1 T1-507510	TAP2 T1-510520	TAP3 T1-520530	TAP5 T1-913520	TAP5v T1-913520	TAP9 T1-913915
	X2											
M-600	570											
M-850	795	751		755	735		755			705		703
M-1000	920	876	856	880	860		880	860		830	848	828
M-1200	1'120	1'076	1'056	1'080	1'060		1'080	1'060		1'030	1'048	1'028
M-1600	1'520	1'476	1'456	1'480	1'460	1'426	1'480	1'460		1'430	1'448	1'428
MMV-1100	1'030	986	966	990	970	936	990	970		940	958	938
MMV-1300	1'230	1'186	1'166	1'190	1'170	1'136	1'190	1'170		1'140	1'158	1'138
MMV-1500	1'430	1'386	1'366	1'390	1'370	1'336	1'390	1'370		1'340	1'358	1'338
MMV-1800	1'780	1'736	1'716	1'740	1'720	1'686	1'740	1'720	1'686	1'690	1'708	1'688
MMV-2000	1'980	1'936	1'916	1'940	1'920	1'886	1'940	1'920	1'886	1'890	1'908	1'888

	TAP9v T1-913918	TOP1 T1-507510	TOP2 T1-510520	TOP3 T1-520530	TAP1c.2 T1-507510	TAP2c.2 T1-510520	TAP3c.2 T1-520530	TAP1.2 T1-507510	TAP2.2 T1-510520	TAP3.2 T1-520530	TOP1.2 T2-507510	TOP2.2 T2-510520	TOP3.2 T2-520530
	X2												
M-600													
M-850													
M-1000		880			880								
M-1200		1'080			1'080								
M-1600	1'447	1'480	1'460		1'480			1'480			1'480		
MMV-1100	957	990	970		990			990			990		
MMV-1300	1'157	1'190	1'170		1'190			1'190			1'190		
MMV-1500	1'357	1'390	1'370		1'390			1'390			1'390		
MMV-1800	1'707	1'740	1'720	1'686	1'740	1'720		1'740	1'720		1'740	1'720	
MMV-2000	1'907	1'940	1'920	1'886	1'940	1'920		1'940	1'920		1'940	1'920	

X-mounting

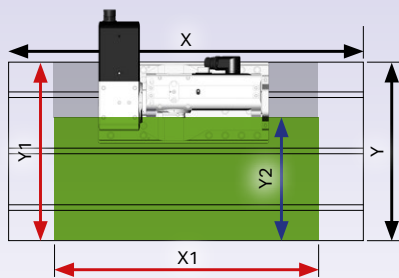

Rotary table installation using hole pattern in base plate

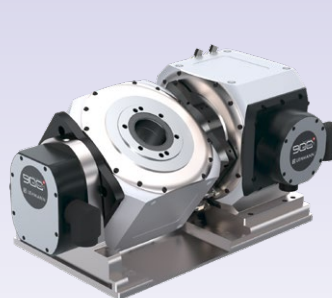

	TIP1c TF-507510	TIP2c TF-510520	TIP3c TF-520530	TAP1c T1-507510	TAP2c T1-510520	TAP3c T1-520530	TAP1 T1-507510	TAP2 T1-510520	TAP3 T1-520530	TAP5 T1-913520	TAP5v T1-913520	TAP9 T1-913915
	Y2											
M-600		276	256	280	260	226	280	260	226	230	248	228
M-850			356			326		360	326		348	
M-1000						386			386			
M-1200						376			376			
M-1600									486			
MMV-1100									476			
MMV-1300									476			
MMV-1500									476			
MMV-1800												
MMV-2000												

	TAP9v T1-913918	TOP1 T1-507510	TOP2 T1-510520	TOP3 T1-520530	TAP1c.2 T1-507510	TAP2c.2 T1-510520	TAP3c.2 T1-520530	TAP1.2 T1-507510	TAP2.2 T1-510520	TAP3.2 T1-520530	TOP1.2 T2-507510	TOP2.2 T2-510520	TOP3.2 T2-520530
	Y2												
M-600	247	280	260		280	260		280	260		280		
M-850	347	380	360	326	380	360		380	360		380	360	
M-1000	407		420	386		420	386	440	420		440	420	
M-1200	397		410	376		410	376	430	410	376	430	410	376
M-1600				486		520	486		520	486		520	486
MMV-1100				476		510	476		510	476		510	476
MMV-1300				476		510	476		510	476		510	476
MMV-1500				476		510	476		510	476		510	476
MMV-1800							776			776			776
MMV-2000							776			776			776



Very good accessibility, even with short tools

More space for workpieces and fixtures

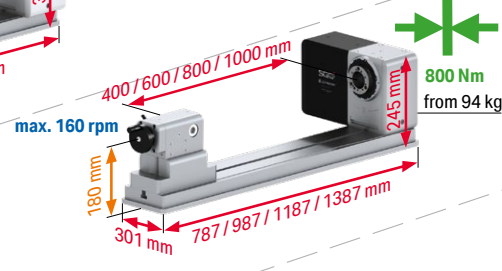
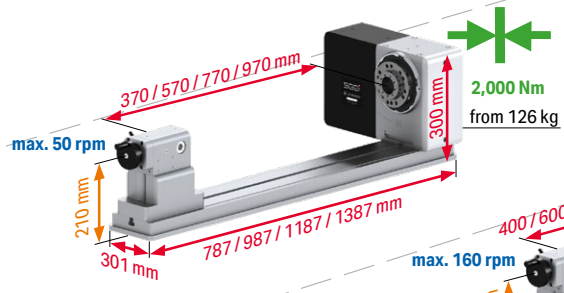
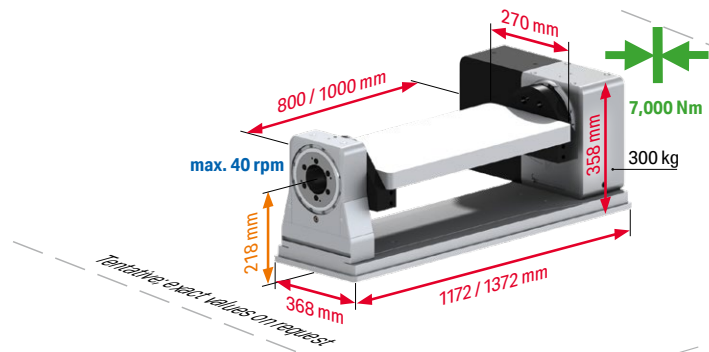
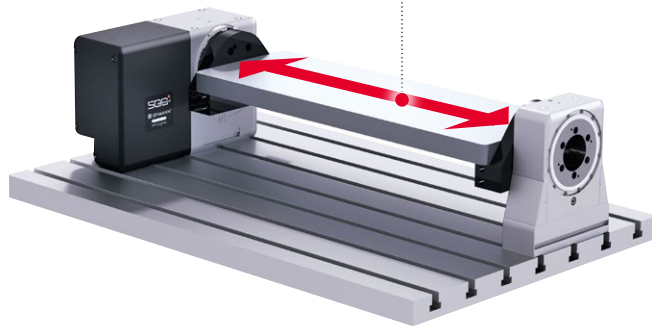

530

520

51x

50x

SIZE

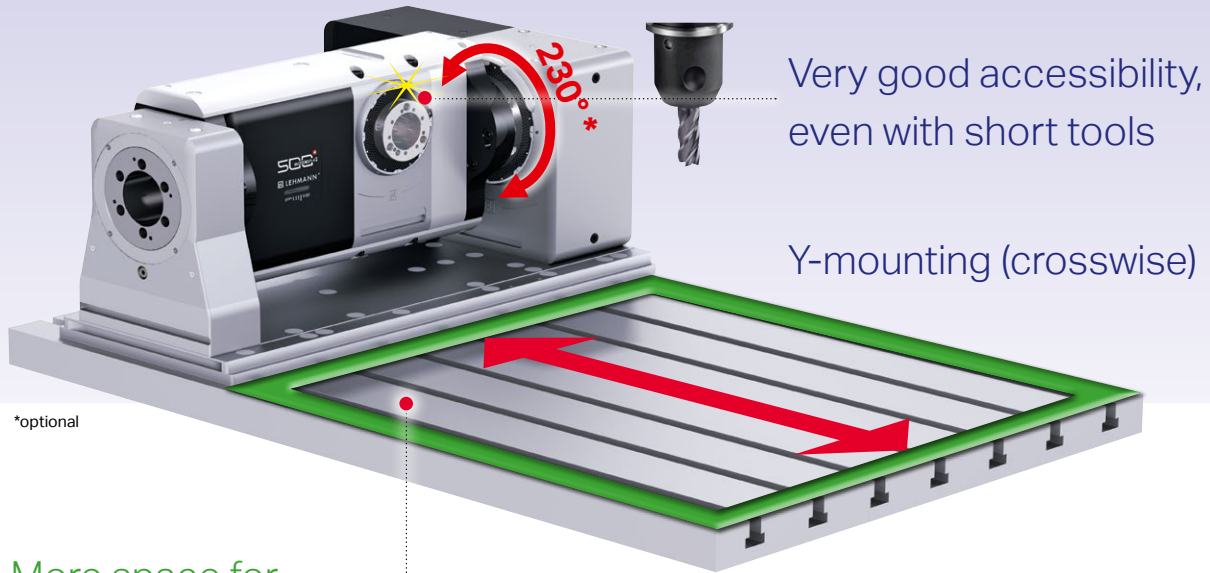

*optional

More space for workpiece and fixtures

Very good accessibility, even with short tools

Y-mounting (crosswise)

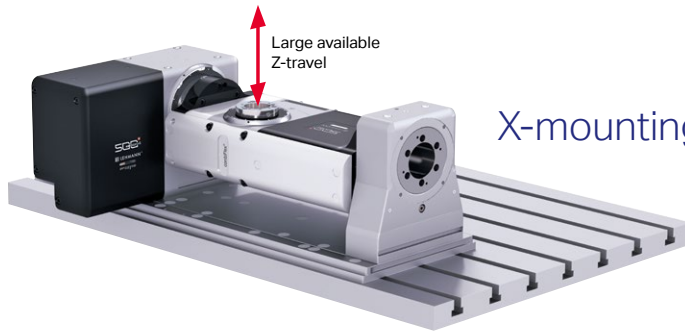

X-mounting (lengthwise)

T1

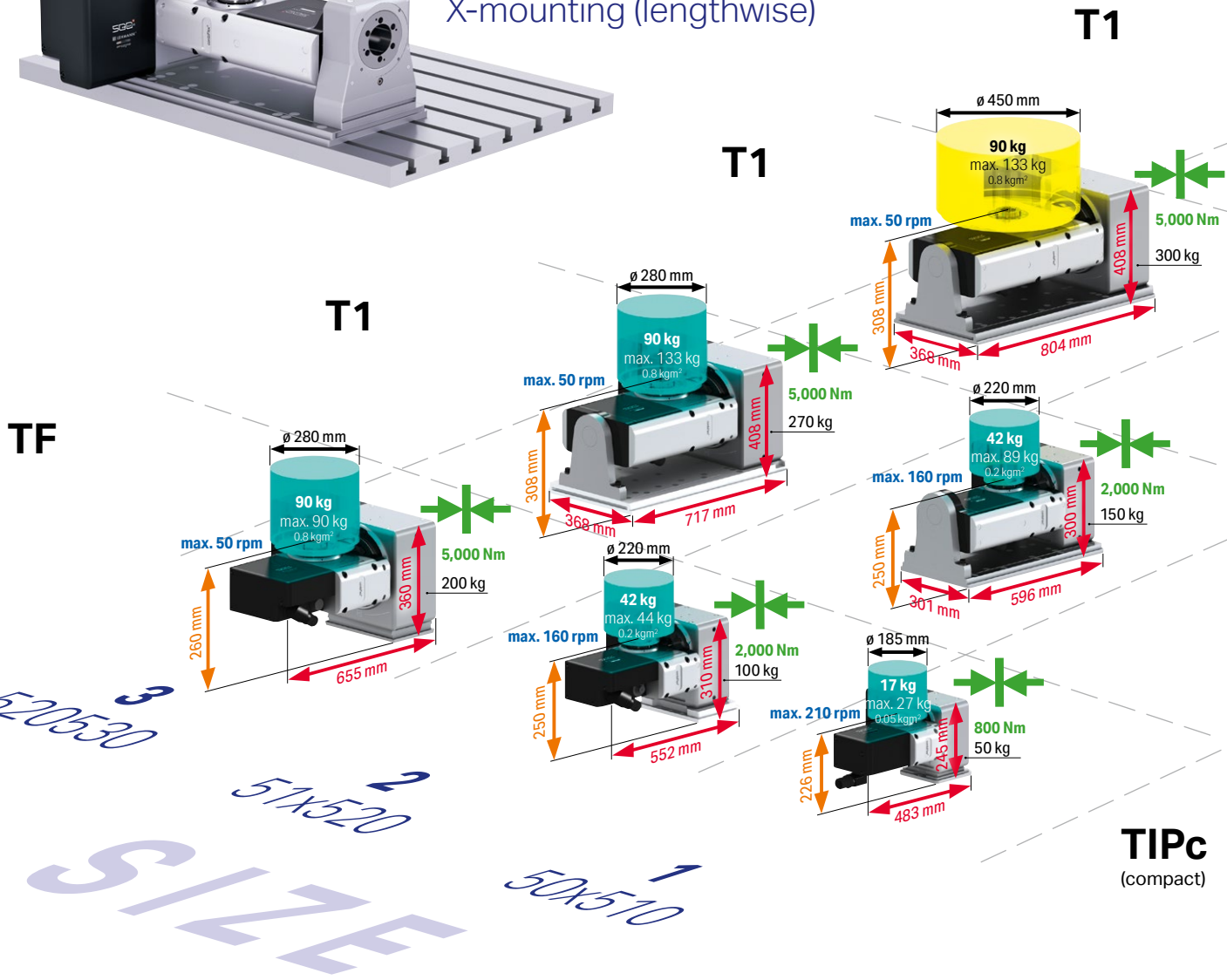

Facts

- Up to 150 % higher clamping torque in tilting axis
- Fewer variant – more solution
- Larger workpiece \varnothing possible
- Spatially optimized arrangement of the dividing axis

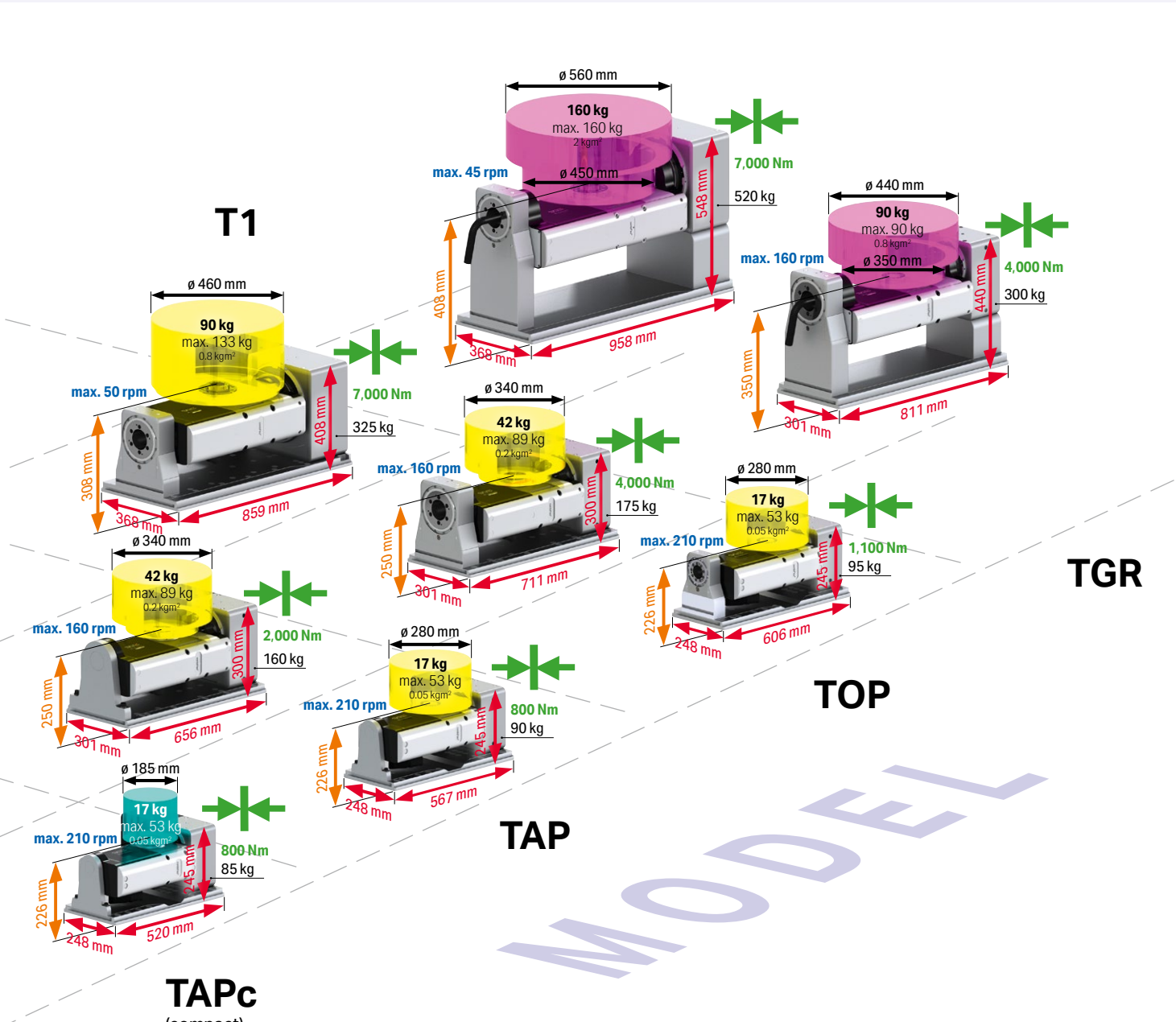

Weight data represent the standard load; higher weights possible, but require modification of rotational speed, acceleration and jerk limitation.

50x510	508510 (standard) or 508510 (high speed)
51x520	510520 (standard) or 511520 (high speed)
TIPc	Two-axis rotary table, no counter bearing, compact
TAPc	Two-axis rotary table, with supporting bearing, compact
TAP	Two-axis rotary table, with supporting bearing
TOP	Two-axis rotary table, with clamped counter bearing
TGR	Two-axis rotary table, with clamped counter bearing, specifically for grinding applications



More space for workpiece and fixtures

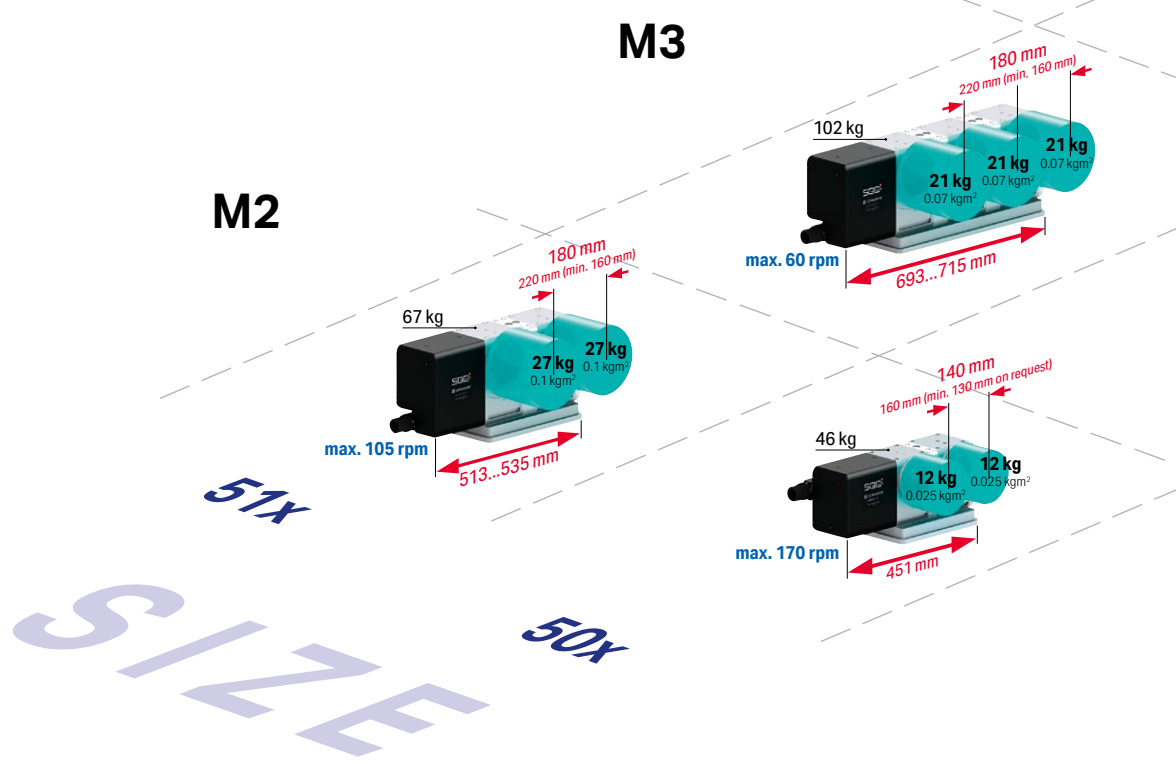

Facts

- Up to 54 % higher clamping torque in tilting axis
- Fewer variant – more solution
- Spindle distance min. 130 mm
- Spatially optimized arrangement of the dividing axis

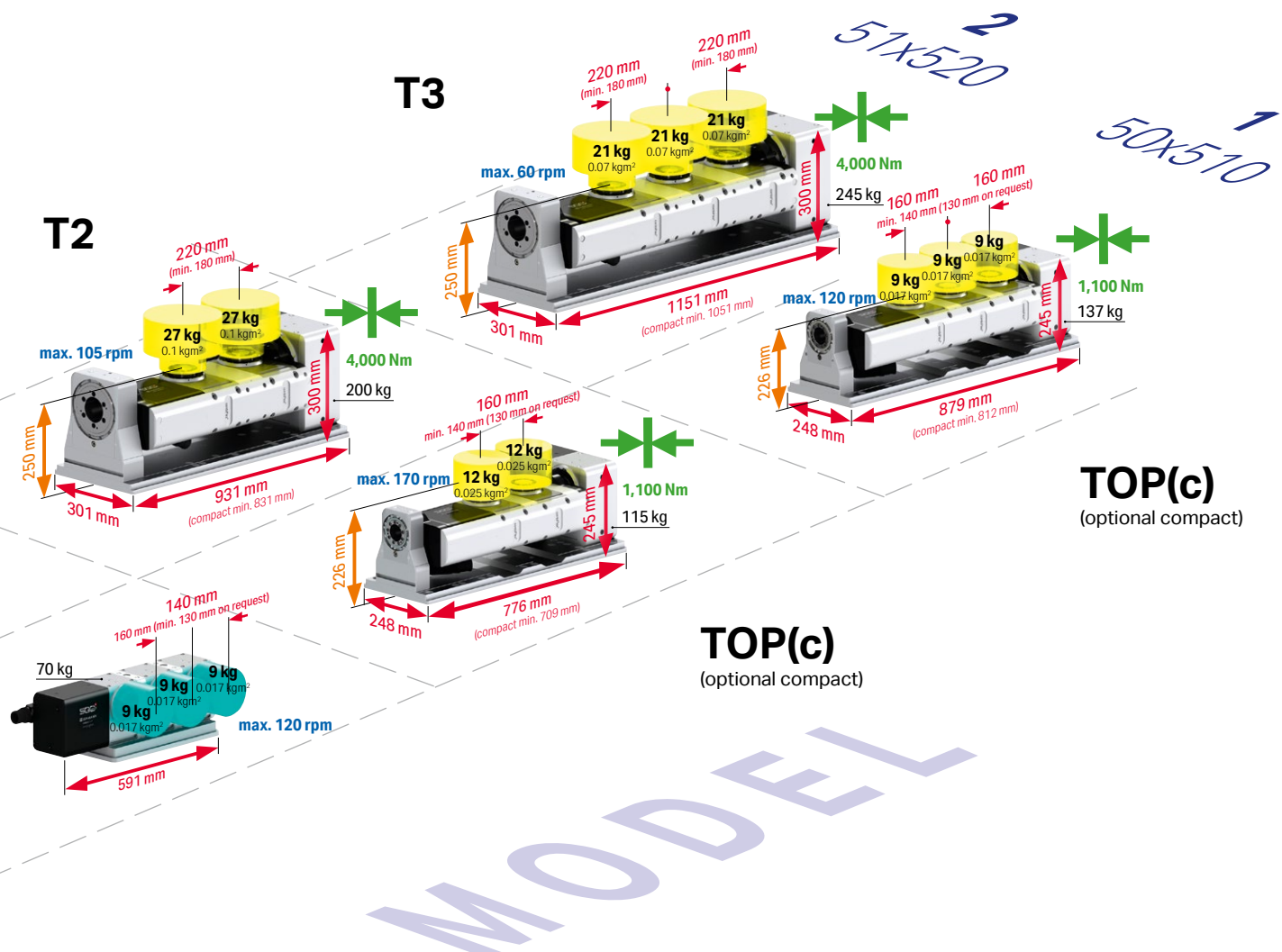

Weight data represent the standard load; higher weights possible, but require modification of rotational speed, acceleration and jerk limitation.

- 50x 507 (standard) or 508 (high speed)
- 51x 510 (standard) or 511 (high speed)
- M2 Single-axis, multi-spindle rotary table, 2-position
- M3 Single-axis, multi-spindle rotary table, 3-position
- T2 Two-axis multi-spindle rotary table, 2-position
- T3 Two-axis multi-spindle rotary table, 3-position

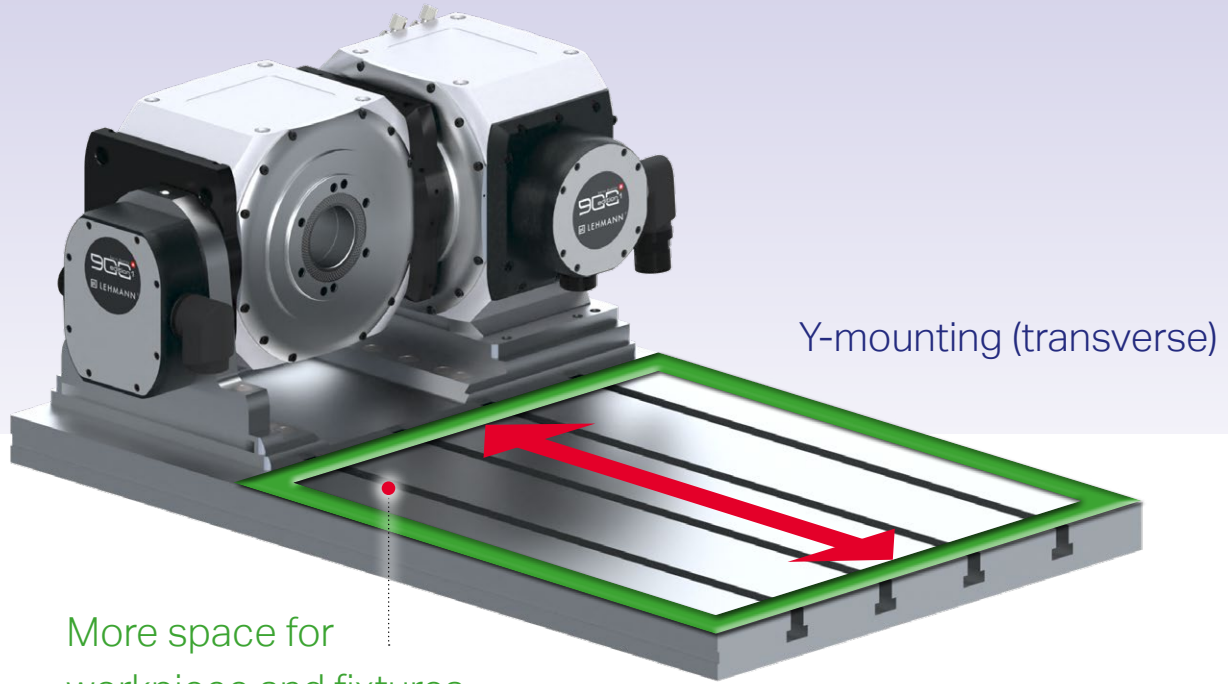

T1

T1

T1

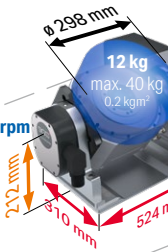

915520

913520

913918

913915

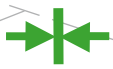
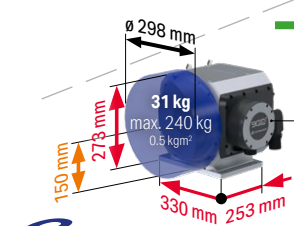

800 Nm
max. 1'300 rpm

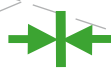
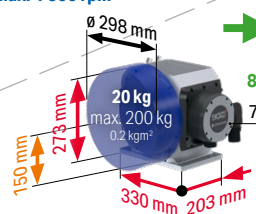

800 Nm
max. 2'560 rpm

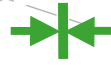
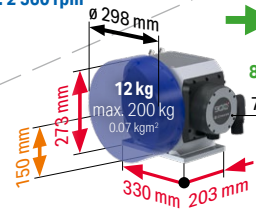

800 Nm
max. 3'210 rpm

918

915

913

EA

SIZE

Highlights

- For millturn applications (e.g. watch cases from bar stock)
- DD up to 3300 rpm available
- Very compact
- For Siemens, Mitsubishi, HEIDENHAIN and Fanuc (if Fanuc measuring system: 100% Fanuc DDT-compatible)

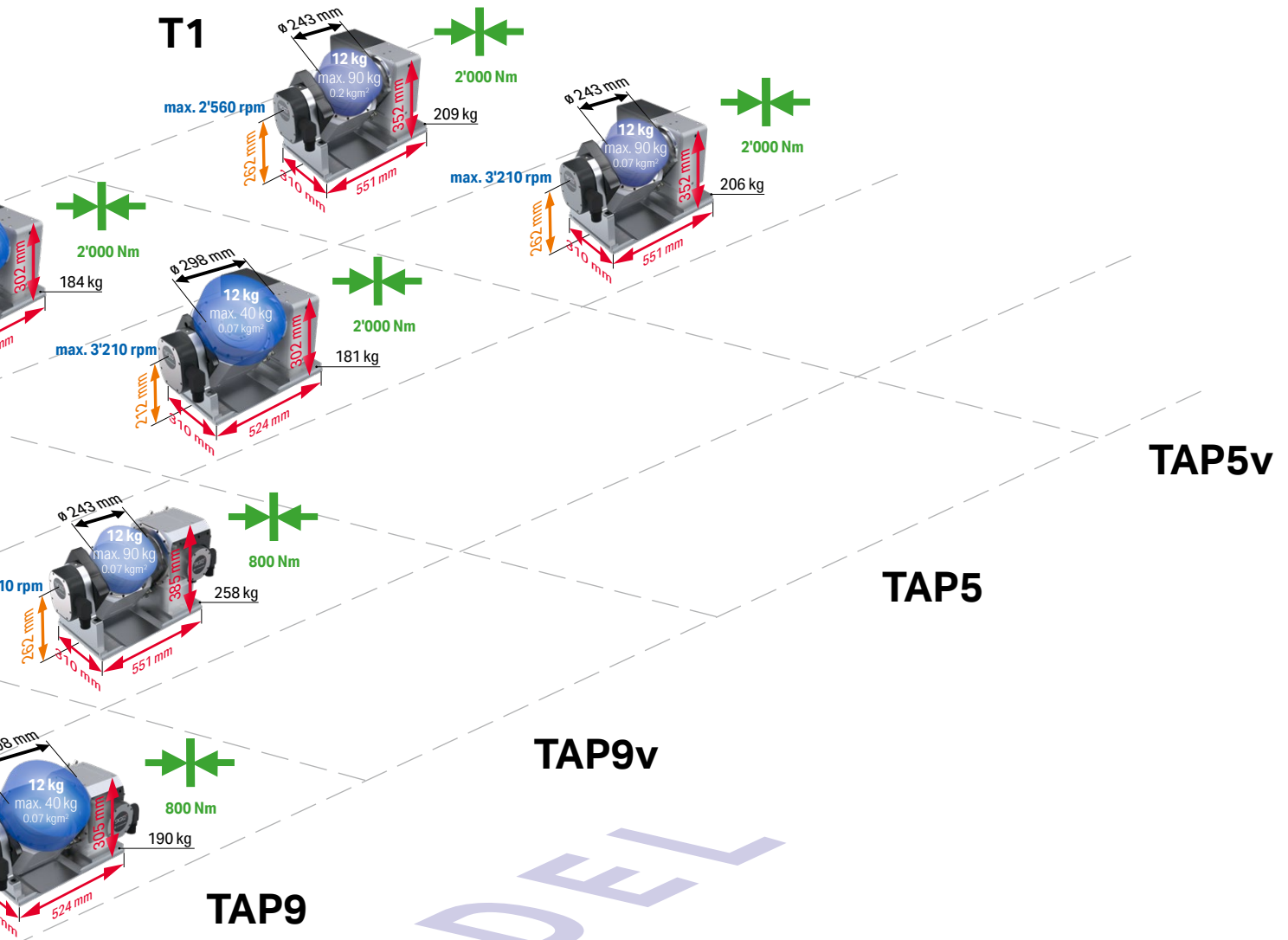

 Weight data represent the standard load; higher weights possible, but require modification of rotational speed, acceleration and jerk limitation.

EA single-axis, single-spindle CNC rotary table
 TAP two-axis rotary table, with supporting bearing
 TAPv Two-axis rotary table, with support bearing, low-profile version (vario)

Feed max.: without flux weakening

Extremely wide assortment for workpiece clamping.
Standardized interface in front and rear:
maximum universality

Spindle accessories, rear

- Rotary unions **up to 250 bar**
- Hydraulic clamping cylinder **23 kN at 120 bar**
- Pneumatic clamping cylinder **11 kN at 10 bar**
- Angular position measuring systems **as precise as ± 1 arcsec**

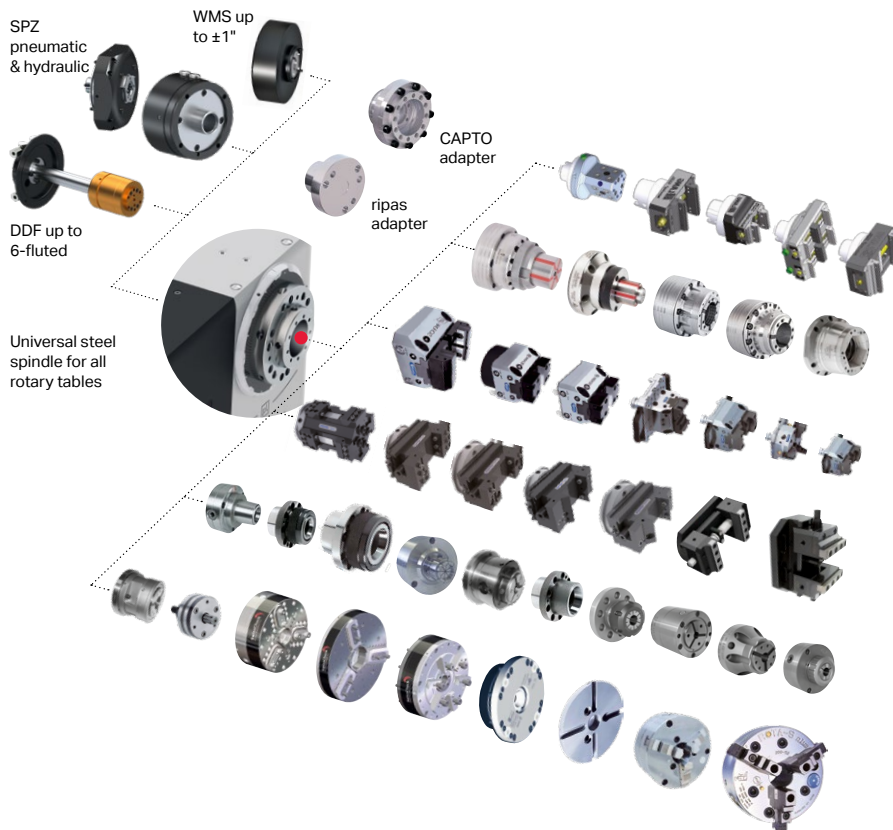

Spindle accessories in front



unique

Tailstocks and counter bearings



ripas zero point clamping system



EA-507 with ripas auto and ripas adapter

CAPTO clamping



EA-507 with CAPTO retrofit kit

Present in over 30 countries:
from sales consultation to the final service



Get an offer

Please send us your request with the following information:

1. Do you need a 4th or 4th/5th axis?
2. On which machine should the rotary table get installed?
(Name and exact type; e.g. SAEILO, M-850)
3. Which controller is on the machine?
(Name and exact type; e.g. Heidenhain TNC 640)
4. What do you want to process on your machine?
 - Workpiece size
 - Weight
 - Material
 - Size of the series (number of pieces/year)
 - Loading and unloading (automatic or manual)
5. Is the machine completely prepared for the 4th or 4th/5th axis
(PLC, software activation, hardware interface)?



ROTARY SOLUTIONS > MACHINE TOOLS & METROLOGY

Headquarters

PETER LEHMANN AG
Bäraustrasse 43
CH-3552 Bärau
Phone +41 (0)34 409 66 66
sales@plehmann.com
www.lehmann-rotary-tables.com

Global network

Europe

- Austria
- Benelux
- Bosnia
- Bulgaria
- Croatia
- Czech Republic
- Denmark
- Estonia
- Finland
- France
- Germany
- Hungary
- Iceland
- Ireland
- Italy

- Kosovo
- Latvia
- Lithuania
- Macedonia
- Norway
- Poland
- Portugal
- Romania
- Serbia
- Slovakia
- Slovenia
- Spain
- Sweden
- Turkey
- UK

America

- Brazil
- Canada
- Mexico
- USA

Asia

- China
- India
- Israel
- Japan
- Malaysia
- Singapore
- South Korea
- Taiwan
- Thailand
- Vietnam

Australia



Legend: Red circle = Headquarters, Green circle = direct sales, Blue circle = pL SOLUTIONS® partner, Yellow circle = value added reseller & partner

More information (address, telephone number...) at www.lehmann-rotary-tables.com